

LEISTER LE Mini Sensor Electric Hot Air Tool



Please read the operating instructions carefully before use and keep for future reference.

USAGE

The LEISTER hot air tool Mini sensor is suitable for building into machines, installations or tools and is designed for continuous operation. The tool offers process safety as a result of the integrated protective elements and interfaces.

- Industrial jointing technology by means of hot air staking
- Different types of drying and warming up processes
- Shrinking and welding of packaging foils and moulds
- Activating and releasing of solvent free glues and fusion adhesives
- Sterilisation of packaging materials such as small bottles, corks and containers
- Smoothing of tablet coatings, glazing of chocolate and cosmetic articles
- Separating and fusing of synthetic threads and fabrics
- Soldering processes on metal parts
- Removal of plastic burrs and glazing of plastic surfaces





WARNING



Danger! Unplug the tool before opening it, as live components and connections are exposed.



Incorrect use of hot air tools can present a **fire and explosion hazard**, particularly in the proximity of flammable materials and explosive gases.



Danger of getting burned! Do not touch the end of the element holder and nozzle when they are hot. Let the tool cool down. Do not point the hot air flow in the direction of people or animals.



CAUTION



The **rated voltage** stated on the tool must correspond with the mains voltage.



The tool must be operated **under supervision**. Heat can ignite flammable materials which are not in view.



Protect the tool **from damp and wet**.

Approval Marks



The tool has been **CCA** certified (CENELEC Certification Agreement)

Electrical safety:  **double insulated**

TECHNICAL DATA		LE Mini Sensor, 400	LE Mini Sensor, 800
Voltage	V~	120 / 230	230
Frequency	Hz	50 / 60	50 / 60
Power consumption	W	400	800
Max temperature	°C / °F	600 / 1112	750 / 1382
Ambient temperature	°C / °F	60 / 140	60 / 140
Min. air flow	l/min	10	10
Max. pressure	Pa	2×10 ⁵	2×10 ⁵
Thermal switch for tool protection		+	+
Heating element protection		+	+
Integrated heating probe		+	+
Analogue interface (passive)	4 – 20 mA	+	+
Weight Mini sensor	g	120	150
Weight, converter	g	190	190
Dimensions, Mini sensor, L × Ø	mm	253×27	308×27
Dimensions, heating tube Ø	mm	15	15
Screwed nozzle joint		⌀ 1/4" × 8	⌀ 1/4" × 8
Dimensions, converter L × W × H	mm	135×105×53	135×105×53

Connection voltage not switchable

Tool description

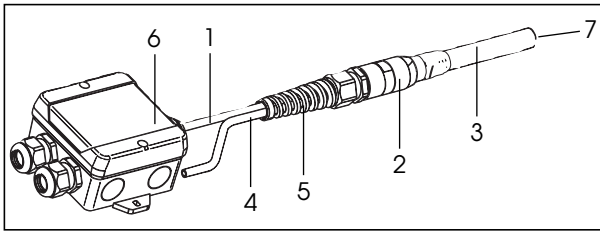

1. Connection lead
2. Housing
3. Heating tube
4. Air inlet
5. Socket protection sleeve
6. Converter
7. Screwed nozzle joint G¹/₄"

LE Mini Sensor Circuit Diagram

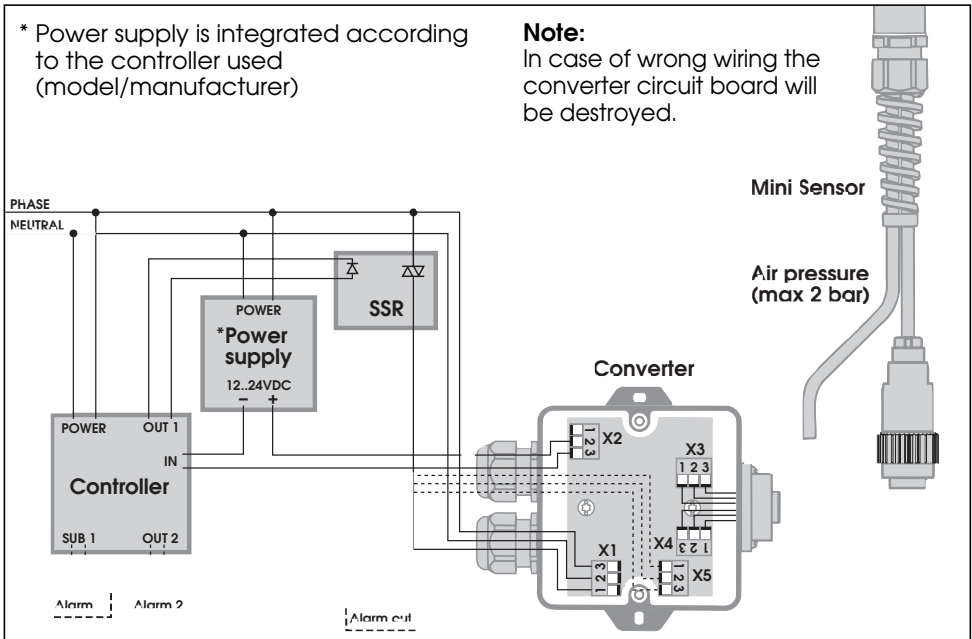

Connections	Description	Terminal 1	Terminal 2	Terminal 3
X1	Power in 100..240VAC	LOAD	NEUTRAL	LINE/MAINS
X2	Sensor out 4..20mA, passiv 4mA $\hat{=}$ 0°C 20mA $\hat{=}$ 1023°C		Positive	Negative
X3	Sensor in thermal element	Earth connection (grey)	Positive (green)	Negative (white)
X4	Power out Heating element	Temperature switch (pink)	Neutral (blue)	Load (black)
X5	Alarm out Relay, 8A/250VAC	Working contact	Connection	Rest contact

Assembling the Mini Sensor

- Assembly must ensure that:
 - only cold air is supplied
 - no (hot air) backup occurs
 - the tool is not subjected to a hot air flow from another tool
- The tool is protected against mechanical vibration and shaking
- No air blasts at temperatures over 100°C
- Assembly dimensions in mm

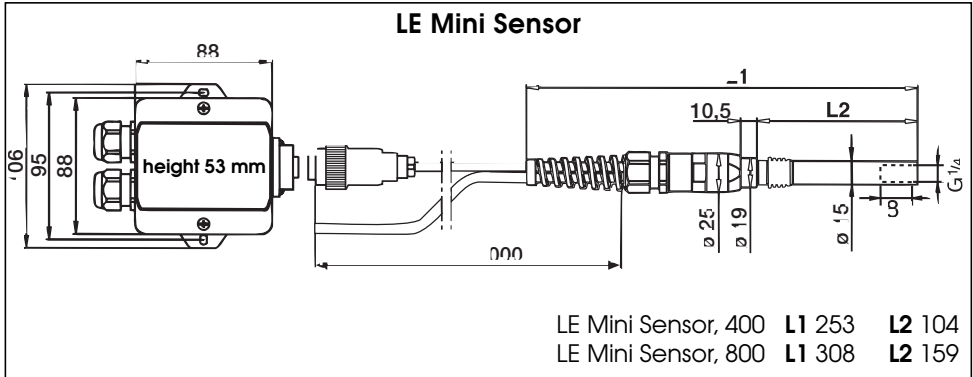

Air supply

- When using compressed air, a pressure reduction valve and an oil and water separation unit must be in the supply
- The air flow can be adjusted by means of an air flow regulator
- The tool must only be supplied with air up to a max. 60°C

Operation

- The tool must be connected by a qualified electrician in accordance with the circuit diagram on page 3
- Fit the nozzle appropriate to the use
- Adjust pressure reduction valve in accordance with the technical details on page 2
- Connect the air supply by means of the pneumatic hose
- Adjust the air flow by means of an air flow controller or pressure reduction valve
Caution: Keep to the minimum air flow according to the technical details on page 2
- Switch on mains
- Allow tool to cool down after use

CAUTION: never operate tool without air!

Function heat element protection

- If the heating element overheats, the heating is switched off by means of the converter. The switching- off can be evaluated by the customer using connection X5 (page 3).

Function tool protection

- If the tool overheats, the heating is switched off by means of the converter. The switching- off can be evaluated by the customer using connection X5 (page 3).

Function analogue interface

- A galvanically isolated signal proportional to the air temperature is available to the customer by means of the 4.20 mA passive current loop.
Value range: 4mA corresponds to 0°C / 032°F
20mA corresponds to 1023°C / 1874°F

Measures to be taken if the heating element or tool protection trips

- Remove tool from mains (LINE/MAINS). The electronics are automatically reset after 5 seconds
- Check air supply
- Check air volume
- Check air flow
- Re-connect tool to the mains

TRAINING

LEISTER Process Technologies and its authorised Service Centres offer free of charge courses in the range of applications on page 1.

ACCESSORIES

- Only LEISTER accessories should be used.
- Let the tool cool down before changing the nozzle or reflector

SERVICE AND REPAIR

- Repairs should only be carried out by authorised **LEISTER Service Centres**. They guarantee a correct and reliable **repair service within 24 hours** using original spare parts in accordance with the circuit diagrams and spare parts lists.

GUARANTEE AND LIABILITY

- Guarantee and liability are in accordance with the guarantee certificate as well as with the currently valid general business and sales conditions.
- LEISTER Process Technologies rejects any guarantee claims for tools which are not in their original condition. The tools must never be altered or changed.

Technical data and specifications are subject to change without prior notice.

Your authorized Service Centre is: